

D) Drill head overhaul

1. Run the drill head until the lubricating oil is warm
2. Stop the engine before servicing the drill head
3. Ensure that the main switch on the engine is on "**OFF**" and locked-out (padlock)
4. Clean around the oil drain, fill, and check locations
5. Look for oil leaks and damage
7. Under the drain location, place a container that is large enough to hold the combined volumes of oil in both the transmission and head gearbox
8. Remove the drain plug
9. Look for metal particles on the magnetic end of the drain plug

IMPORTANT: If you find any metal particles on the magnetic end, immediately advise your service department and await instructions.

10. Remove the transmission and the transmission adaptor plate

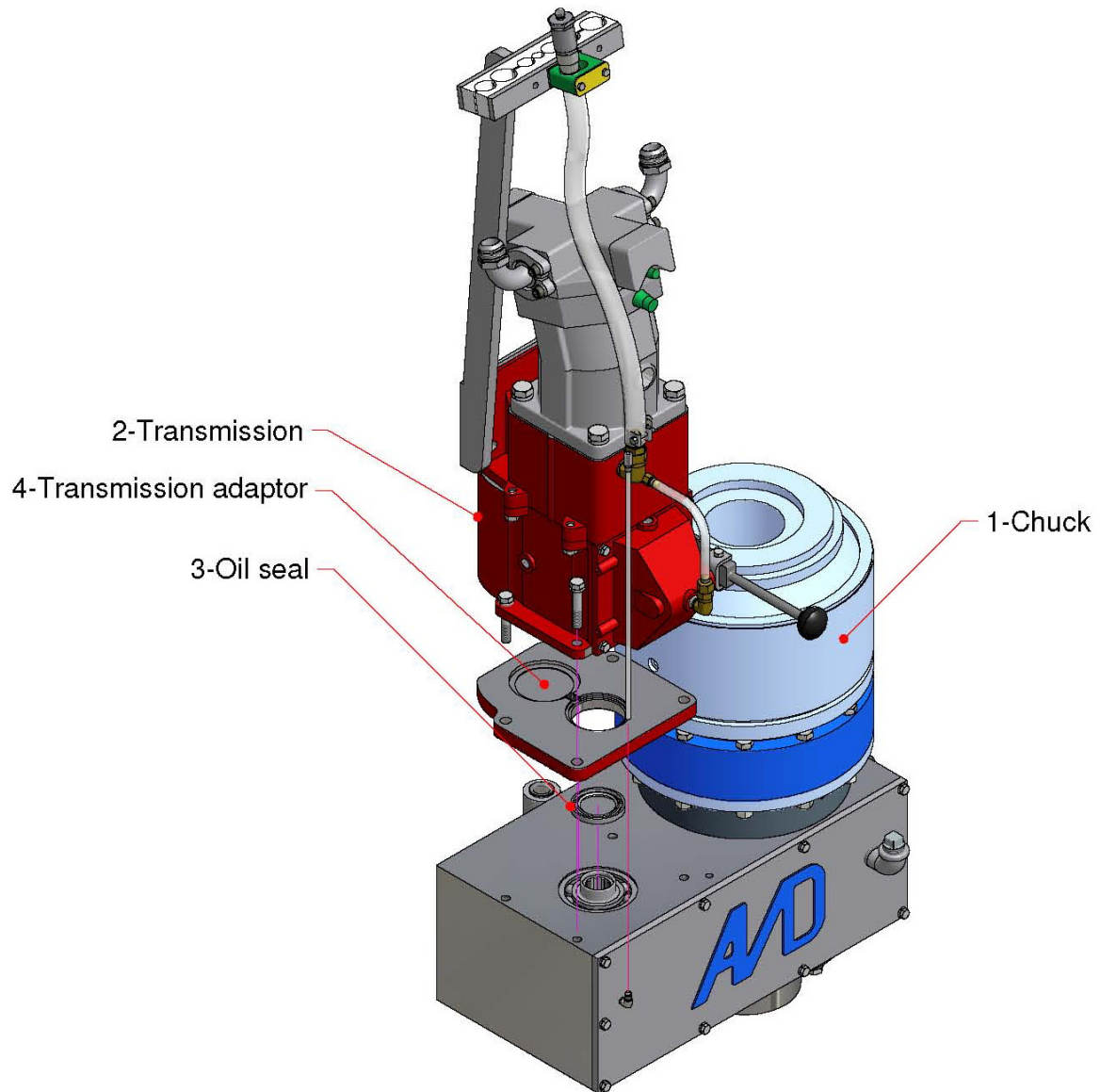

TRANSMISSION REMOVAL

11. Remove the retaining ring and Gib head keys (3) that lock the spindle to the chuck.

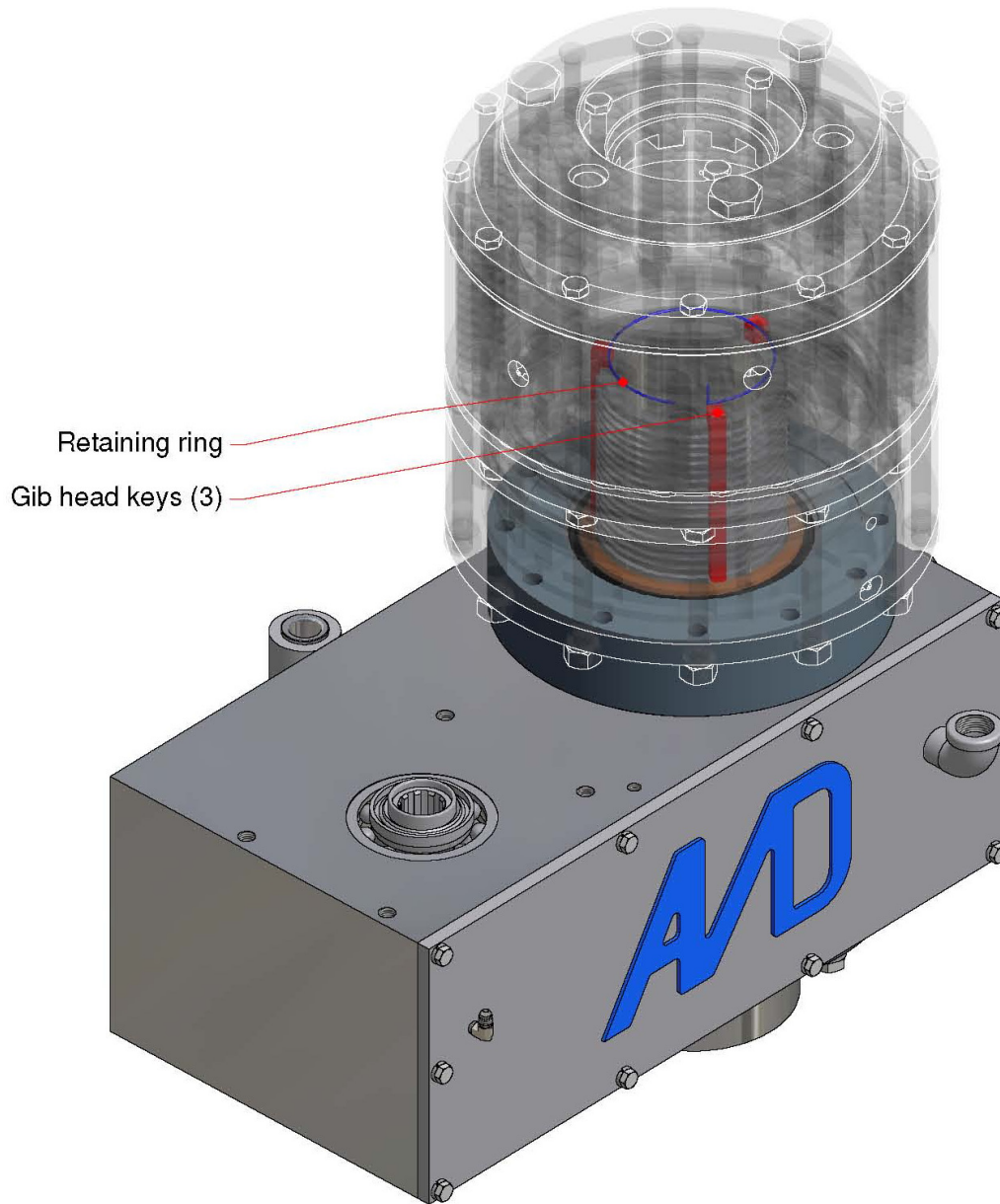

CHUCK REMOVAL

12. Unscrew all nuts identified in the picture
13. Remove the chuck from the gearbox

Note: To remove the chuck, you will require three eyebolts and the chuck removal tool. Install the eyebolt and attach the chuck to a bridge crane or any other device that will support the weight of the chuck (Chuck "P" 210kg (460lbs), Chuck "H" 114kg (250lbs)). Use the removal tool to unscrew the chuck from the spindle.

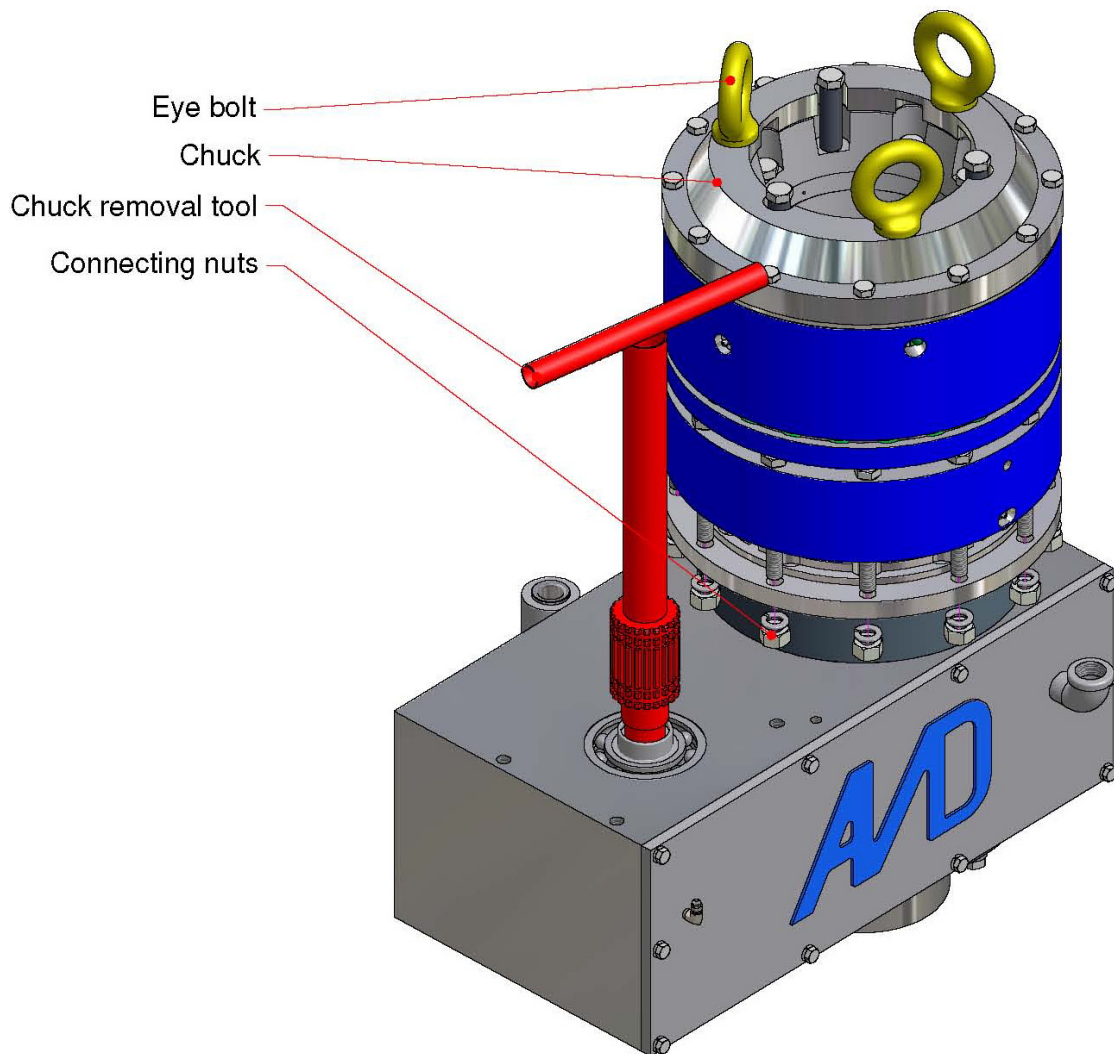

CHUCK REMOVAL

14. Remove the gearbox cover plate
15. Remove the chain and check it for premature wear or damage
16. Disassemble the drill head transmission shaft assembly

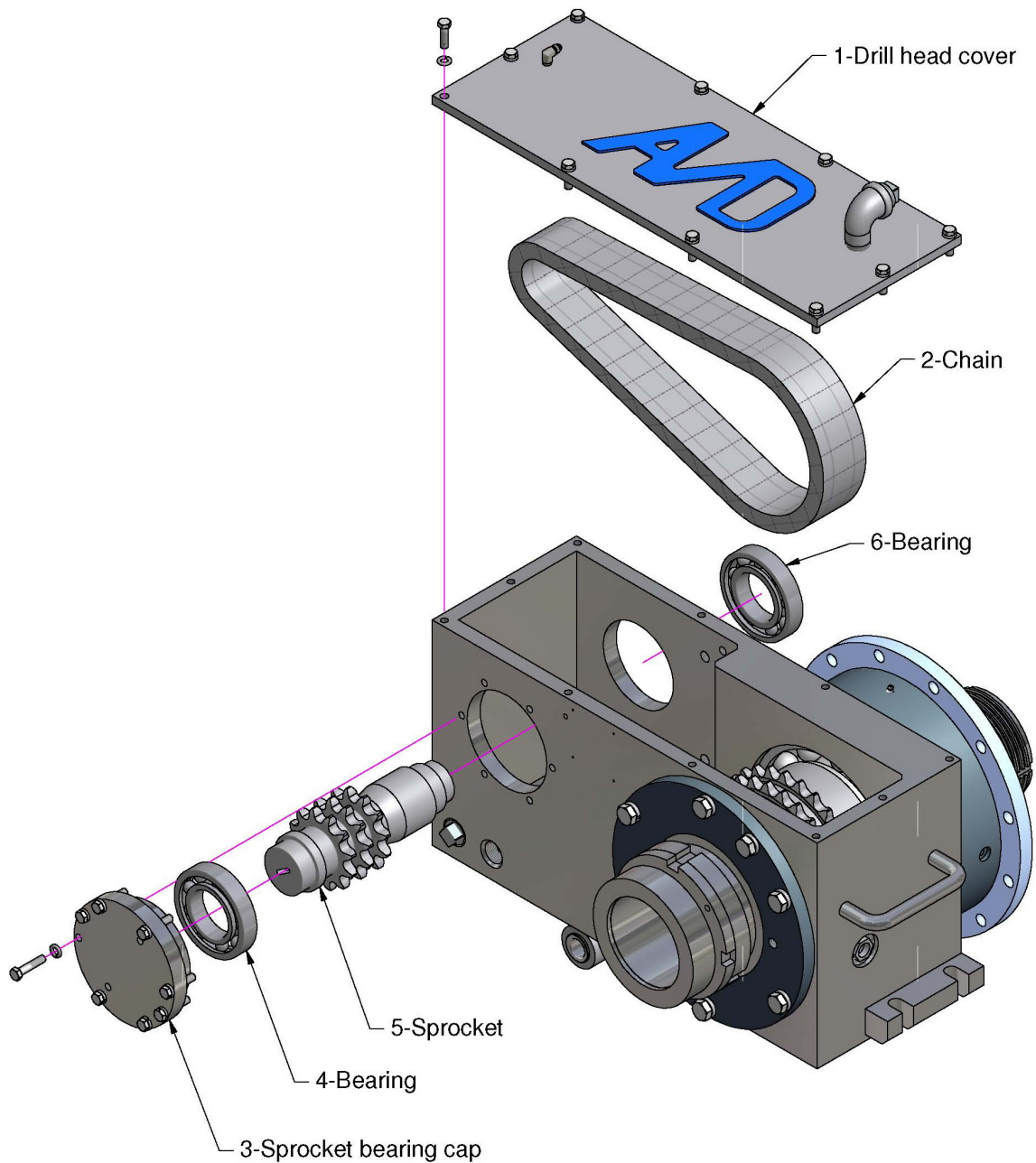

COVER PLATE AND DRILL HEAD TRANSMISSION SHAFT ARRANGEMENT

- 17. Remove drill head lower spindle retaining ring
- 18. Remove drill head upper spindle retaining ring

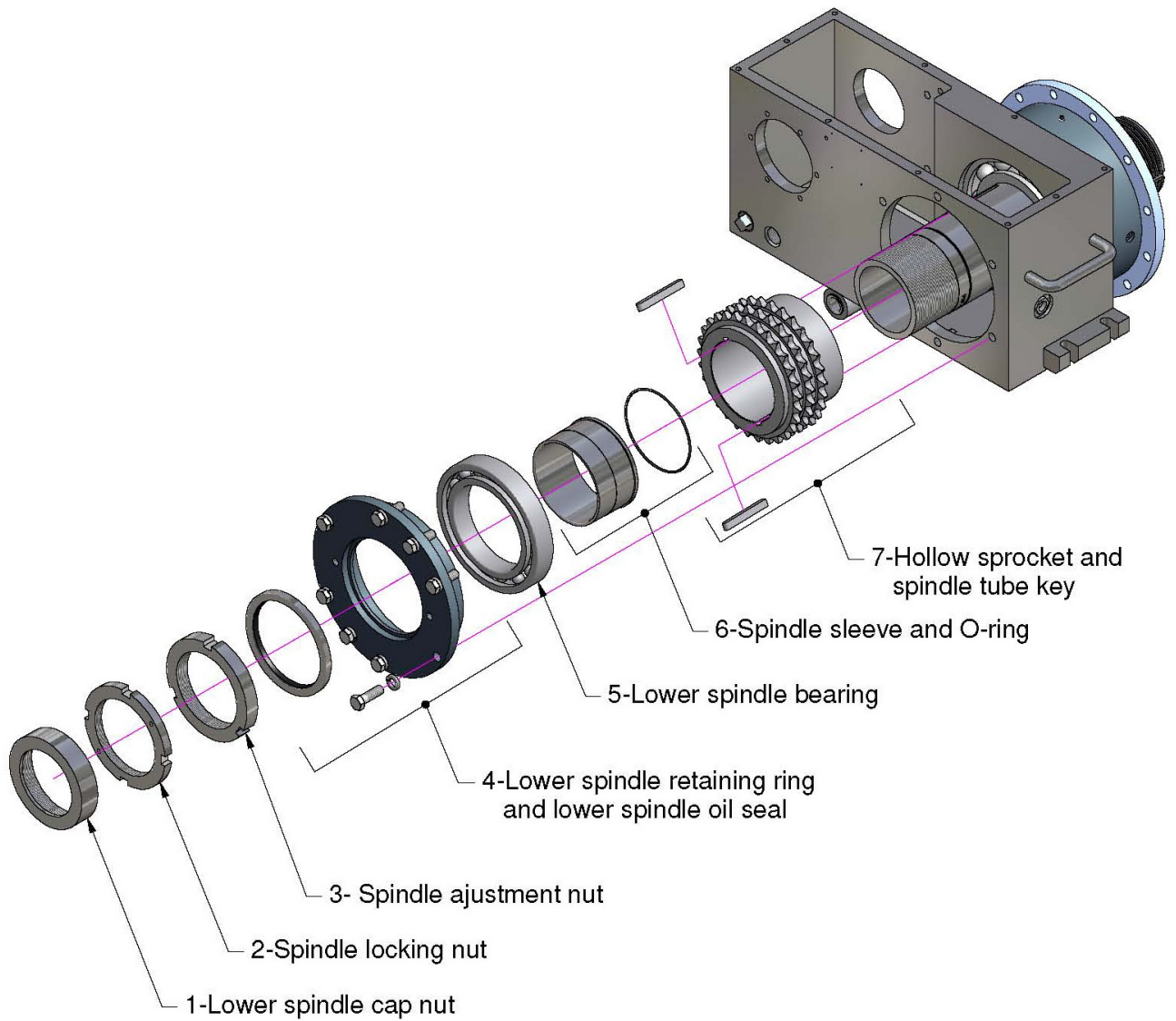

DRILL HEAD LOWER SPINDLE ASSEMBLY

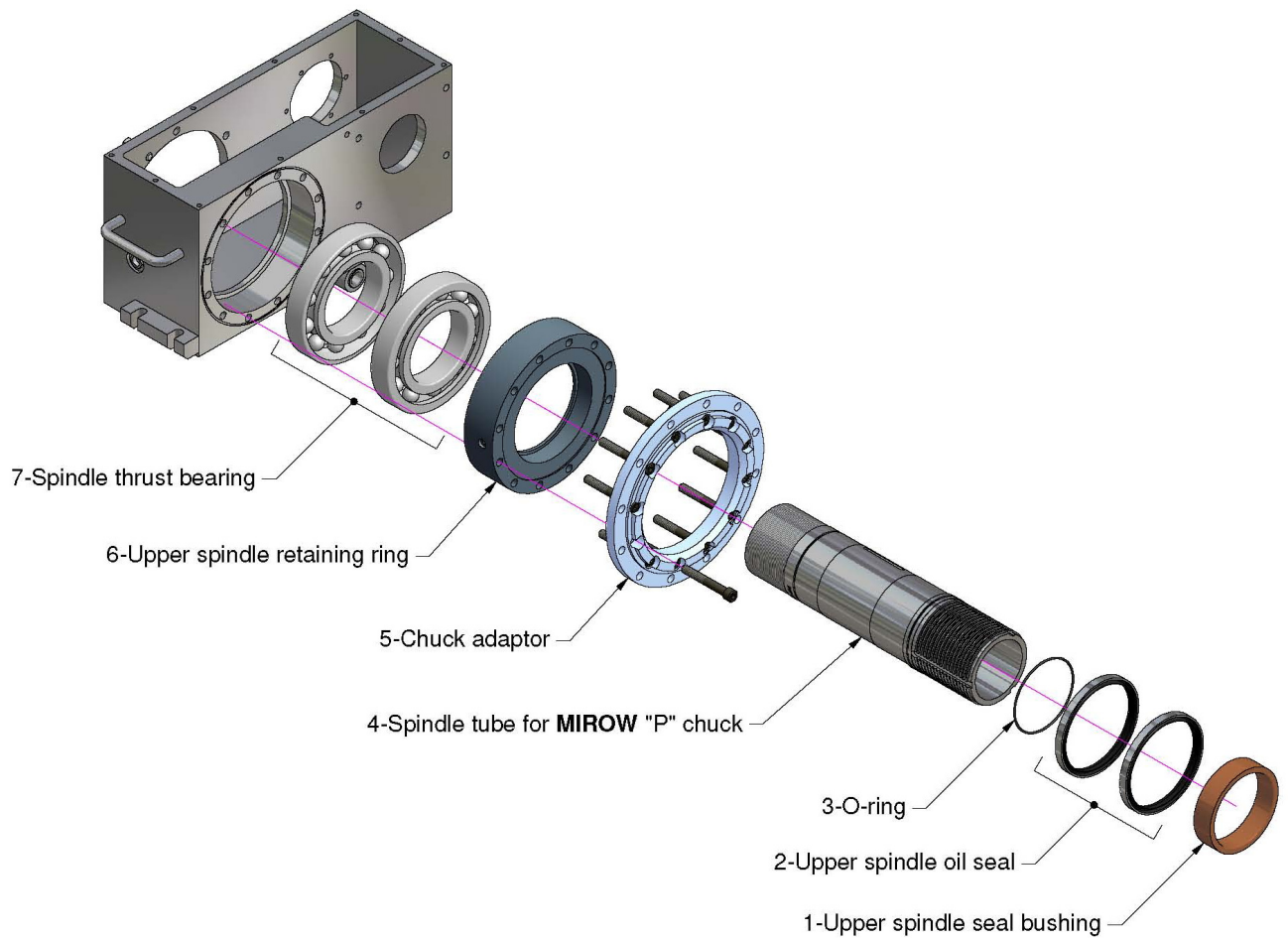

DRILL "P" HEAD UPPER SPINDLE ASSEMBLY

19. Clean thoroughly the inside of the gearbox and parts with the appropriate product
20. Re-assemble the drill head with the new bearings

IMPORTANT: The spindle and transmission thrust bearing must be installed in a specific manner to function properly. Refer to your maintenance department for instructions.

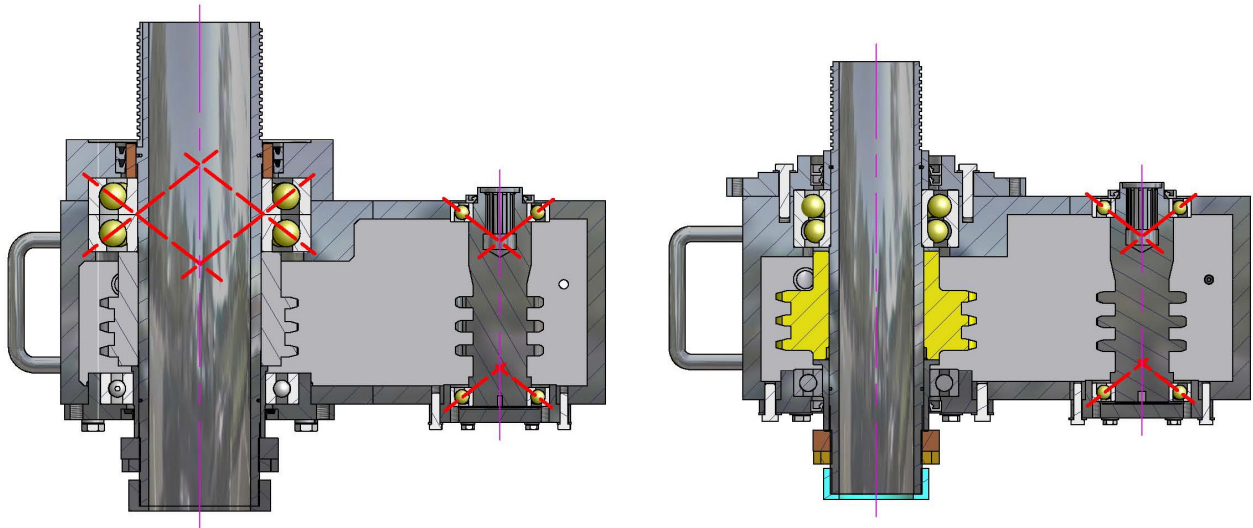

"P" DRILL HEAD

"H" DRILL HEAD

To ensure longer life it is very important to keep the new bearings and seals clean during installation.

Pack the new bearing with a liberal amount of bearing grease before installation.

To prevent oil leakage: apply any gasket-related product (ex. Loctite Gasket Eliminator 518) on the sprocket bearing cap, lower, upper spindle retaining ring and screws before assembly. Control the amount of product you use to prevent overflow inside the drill head.

Check or replace the oil seal and "O"-ring with new ones to prevent oil leakage coming from used/damaged seals.

21. Re-install the chuck

IMPORTANT: Do not forget to replace the retaining ring and the gib head keys (3) that lock the spindle with the chuck.

22. Use the spindle adjustment nut to tighten the spindle and the thrust bearing assembly

23. Use the locking nut and the cap nut to finalize the assembly

IMPORTANT: Pay special attention during this operation to ensure that the nuts are well-tightened. If not, the spindle thrust bearing could be seriously damaged. During

normal operations, this should be repeated several times during the first shift. Then, once at the beginning of each shift should be sufficient.

24. Clean all parts and install the cover plate and the drain plug.

IMPORTANT: To prevent oil leakage, apply any gasket-related product (ex. Loctite Gasket Eliminator 518) between the cover plate and the drill head. Limit the amount of product you use to prevent overflow inside the drill head.

25. Re-install the transmission and adaptor plate

IMPORTANT: To prevent oil leakage, apply any gasket-related product (ex. Loctite Gasket Eliminator 518) between the adaptor plate and the drill head. Limit the amount of product you use to prevent overflow inside the drill head through the bearing.

26. Refill transmission and gearbox with oil.

IMPORTANT: Do not overfill. Too much oil will cause the transmission/gearbox to overheat. Run the drill head for at least one minute at maximum RPM (4th gear on FUNK transmission). This will ensure proper lubrication of the drill head bearing.

27. Operate the drill head for several minutes. Look for oil leaks and listen for unusual sounds.